

PAPER • OPEN ACCESS

## Design and optimization of a cold compressor impeller in a large superfluid helium cryogenic system

To cite this article: L Zhang *et al* 2019 *IOP Conf. Ser.: Mater. Sci. Eng.* **502** 012199

View the [article online](#) for updates and enhancements.



**IOP | ebooks™**

Bringing you innovative digital publishing with leading voices to create your essential collection of books in STEM research.

Start exploring the collection - download the first chapter of every title for free.

# Design and optimization of a cold compressor impeller in a large superfluid helium cryogenic system

L Zhang<sup>1,2</sup>, Z Zhang<sup>1</sup>, S Li<sup>1</sup>

<sup>1</sup>Institute of High Energy Physics, CAS, Beijing 100049, China;

<sup>2</sup>University of Chinese Academy of Sciences, Beijing 100049, China

[zhanglei92@ihep.ac.cn](mailto:zhanglei92@ihep.ac.cn)

**Abstract.** As the scale of superconducting accelerator construction grows, superfluid-helium systems providing the cryogenic environment for them are increasingly widely used. Most of the large-scale superfluid-helium system in international accelerator laboratories use the cold compressor as a pressure generating device. The impeller is the critical component of the cold compressor. Cfturbo® is adopted here to design the impeller and its 3D model is shown. CFD (Computational Fluid Dynamics) is used for simulation of the performance of the designed impeller. This paper analyses the simulation results and the distribution of the flow field, and explores how impeller performance varies as structure parameters change, thus optimizing the impeller. Simulation results of the optimized impeller indicate good performance, which should enable it to meet its design requirements.

## 1. Introduction

A particle accelerator is a facility to accelerate charged particles based on electromagnetic fields. It has been widely applied to physics research since the early 20<sup>th</sup> century and has greatly promoted the development of accelerator physics and technology. Nowadays, the accelerators constructed in most of the international accelerator laboratories around the world adopt superconducting technology. Superconducting cavities and magnets are key components of superconducting accelerators and these need large-scale superfluid-helium cryogenic systems to provide their cryogenic environment. As the scale of superconducting accelerator construction enlarges, 2 K superfluid-helium cryogenic refrigeration technology is more widely used. Figure 1 is the flow chart of a 2 K cryogenic system. 4.2 K liquid helium generated by the refrigerator flows through a cryogenic and sub-atmospheric heat exchanger, exchanging heat with returning 2 K helium gas; it is subsequently throttled and becomes 2 K superfluid helium after passing through the J-T valve. The 2 K superfluid helium – the saturation pressure of which is 31 mbar – is pressurized by a set of cold compressors and exchanges heat with the warm stream through a heat exchanger in the refrigerator. Finally it is pressurized again by pumps, which raise the pressure to 1.05 bar before the gas passes into the inlet of the compressor in the refrigerator.

Nowadays, most of the large-scale superfluid-helium systems in international accelerator laboratories have used a cold compressor. Because of the characteristics of high rotation speed and high rotation precision, as well as the cryogenic and sub-atmospheric working conditions, it is very difficult to design and manufacture a cold compressor. A cold compressor is composed of room-



temperature and low-temperature working parts. There are actuating devices, bearings and a frequency controller in the room-temperature part; the low-temperature part contains the impeller, diffuser and volute. The impeller is a key component of a cold compressor and the only part to do work on the fluid. In this paper, Cfturbo® – a professional software tool used to design the rotating machinery – is applied to design the impeller and its 3D model is shown. CFD is used to simulate the performance of the designed impeller. The paper goes on to analyse the simulation results and distribution law of the flow field, explores how impeller performance varies as structure parameters change, and thus optimizes the impeller.

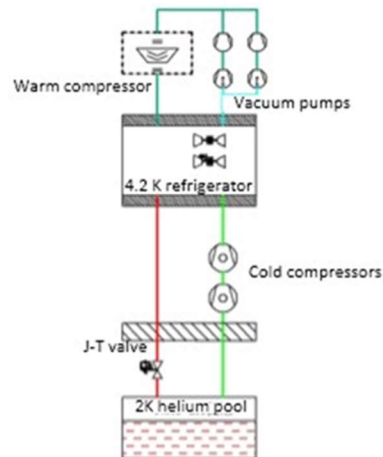

**Figure 1.** 2K cryogenic system flow diagram.

## 2. Design of the impeller

### 2.1. Design parameters of impeller

Prior to entering the impeller, the 2 K saturated gas helium returning from the liquid helium pool exchanges heat with 4.2 K liquid helium from the refrigerator. The pressure drop experienced by the gas in the shell side of the heat exchanger is about 100 Pa. The design pressure of helium entering impeller entrance is 3000 Pa, the design temperature is 3.5 K and the mass flow is 20 g/s. The design speed of the impeller is 50000 rpm and the required pressure ratio is 3.

The type of impeller plays an important role in its performance, and it is selected according to the characteristics required. The backward-bladed, unshrouded type and three-dimensional warping blade impeller is selected in this study. Low-temperature steel is chosen as the material of the impeller.

### 2.2. Designing the impeller

Cfturbo® is the professional software used to design the impeller and volute. It incorporates a wide range of turbo machinery equations and has a history of successful use in impeller design. Within the design, flow, rotational speed, pressure ratio and specific speed are computed and thus the flow type of the gas is determined. Specifying the impeller inlet diameter, hub diameter and impeller diameter allows the meridian plane of the impeller to be defined according to an empirical function contained within the software. The meridian plane parameter and blade aerodynamic parameter having been determined, the discharge section area, the static moment curve and the distribution of axial velocity are adjusted allowing the software to determine the impeller passage with the best performance automatically. In the present design, an inlet diameter of the impeller of 50 mm and blade outlet height of 5 mm are selected. The number of both the main blades and the splitter blades is 9. The centre line of the blade – that is to say, the ligature from the center of blade inlet to outlet – is selected as a Bezier curve. The blade inlet adopts rounding to reduce gas flow losses. The thickness of the blades from leading edge to trailing edge is kept the same. The designed impeller is shown in figure 2.

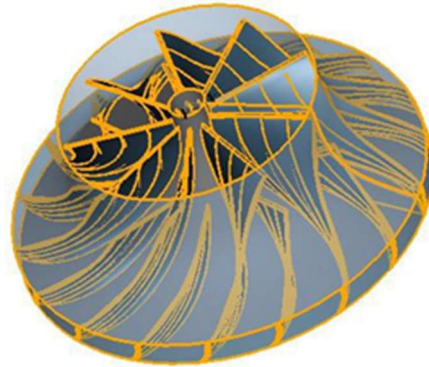
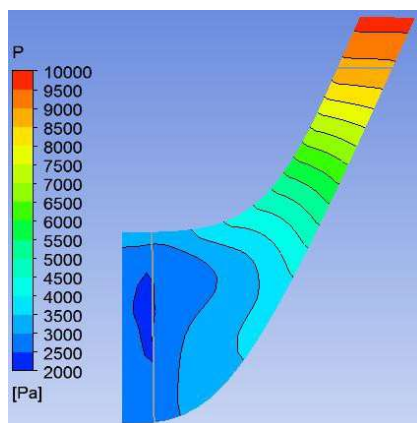

**Figure 2.** Initial design model of impeller.

### 3. Simulation of the impeller

CFD is used for simulation of the designed impeller. The domain discretization is handled by an unstructured grid in the geometric model of a single passage of the cold compressor impeller. Selecting the pressure ratio as a measurement parameter to check how the number of grid cells influences the simulation result of the impeller performance, a 400,000 cell grid was finally chosen. The number of nodes in the grid model is 379,323 and number of the elements is 351,216.

Discrete N-S equations based on a finite volume method are used in the solution. The input boundary conditions are total pressure as well as temperature, and the outlet boundary condition is a defined mass flow. The solution is considered converged when the residual is less than  $1 \times 10^{-4}$  for the same time step, at the pressure monitoring point in the outlet of impeller. The axial boundary of the computing domain adopts a periodic boundary condition. Figure 3 and figure 4 show the distribution of meridian pressure and entropy of the initial impeller design. Simulated result shows that gas flow is uneven and turbulence as well as separation phenomenon are obvious. Therefore the impeller needs to be further optimized according to its flow distribution.



**Figure 3.** Distribution of meridian pressure.

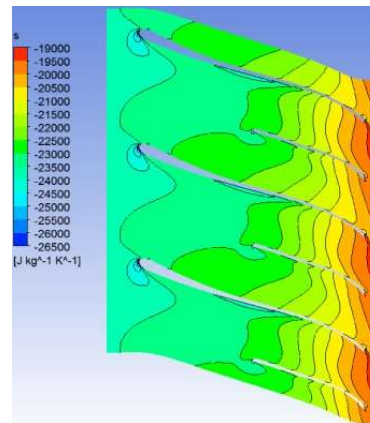

**Figure 4.** Distribution of the entropy.

### 4. Optimization of impeller

The main structure parameters influencing performance of impeller are hub diameter, impeller inlet diameter, impeller outlet height and the number of blades. Figure 5 and figure 6 show the change of pressure ratio as functions of the aforementioned structure parameters.

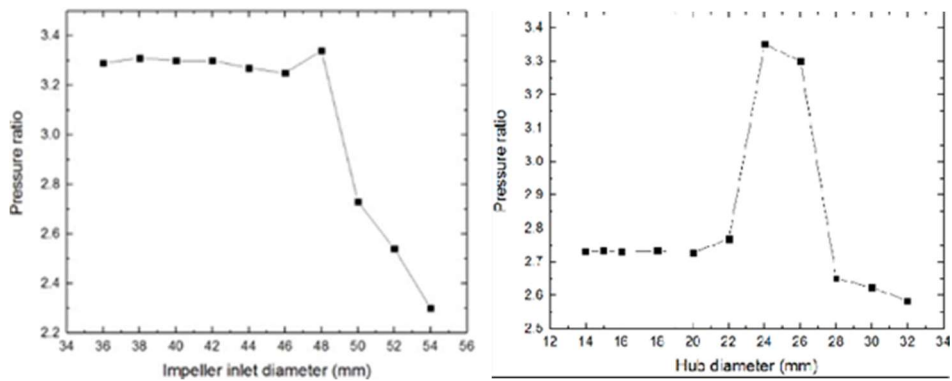

**Figure 5.** Performance of impeller as functions of impeller inlet diameter and hub diameter.

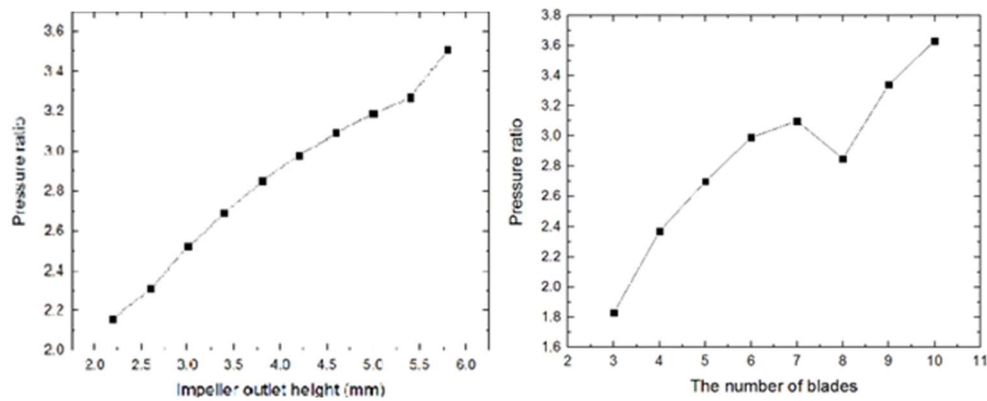
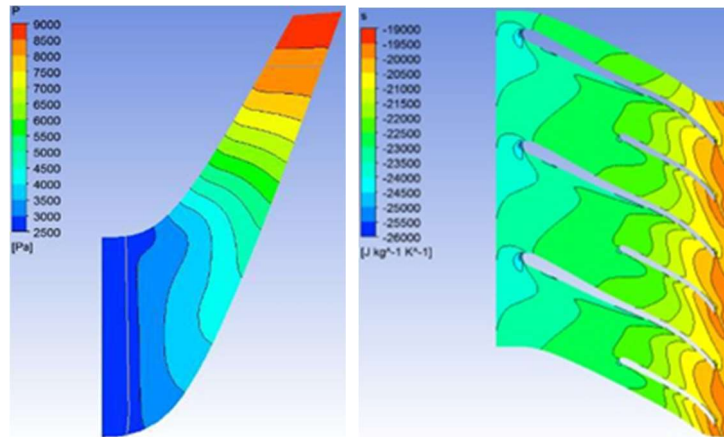

**Figure 6.** Performance of impeller as functions of impeller outlet height and the number of blades.

As is shown in the plots, as the impeller inlet diameter is increased, the pressure ratio changes a little at first, then decreases gradually. As hub diameter increases, pressure ratio increases initially and then decreases. With increasing impeller outlet height, the pressure ratio increases gradually. As the number of blades increases, the pressure ratio increases gradually. Using these results, the following optimum impeller geometry is selected: impeller inlet diameter = 48 mm, hub diameter = 24 mm and impeller outlet height = 4.2mm. Considering manufacturing limitations, the number of blades is selected 12.

## 5. Simulation results analysis

The performance of the optimized impeller is simulated and the resulting pressure ratio is calculated as 3.1. Figure 7 and figure 8 show the distribution of meridian pressure, entropy and gas flow. One can see from figure 8 that the streak lines are smooth and its distribution is even. The pressure ratio is improved. Overall, the results of the optimization are good.



**Figure 7.** Distribution of meridian pressure and entropy after optimization.

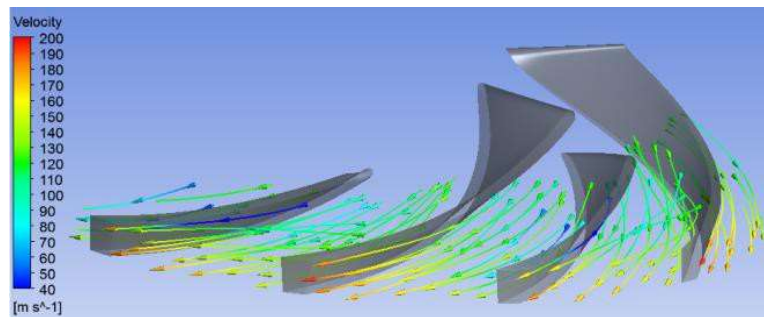

**Figure 8.** Distribution of streak lines in the impeller optimized.

## 6. Conclusion

Cold compressors have the characteristics of high rotational speed as well as cryogenic and sub-atmospheric working conditions. Selection of the type of impeller, which is a critical component of cold compressors, must be made according to the above characteristics. Cfturbo® is used here to design the impeller and the resulting 3D model is shown. CFD is used for simulation of the designed impeller and the simulated results, including the distribution of gas flows, are analysed. This paper has explored how structure parameters, such as impeller inlet diameter, influence the pressure ratio of the impeller and optimised the impeller by using the simulation results. These show that the optimized impeller has better aerodynamic performance and that the impeller meets design requirements.

## Reference

- [1] Lebrun P, Taviani L, Claudet G Development of Large-Capacity Refrigeration at 1.8 K for the Large Hadron Collider at CERN
- [2] Li S, Ge R, Zhang Z, Liu Y, Sang M, Bian L, Han R, Zhang J, Sun L, Xu M, Ye R, Zhang J. Overall Design of ADS Injector I Cryogenic System in CHINA
- [3] Zhenting D Application, improvement and development of the impeller of centrifugal compressor
- [4] Zhong X 1990 *The principle of the centrifugal compressor* (Beijing: China Machine Press)
- [5] Zhang N, Zhang P, Wu J, Li Q 2014 Numerical study of unsteady flow in centrifugal cold compressor *25th Int. Cryo. Eng. Conf. and Int. Cryo. Mat. Conf.*
- [6] Xinde C 2011 *The vane pump ventilator compressor (Principle, design and operation)* (Beijing: China Machine Press)